









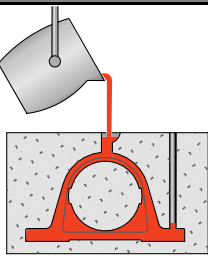

# Rodamientos autoalineables y soportes

Programa estándar

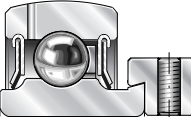
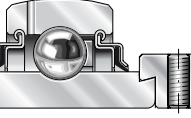
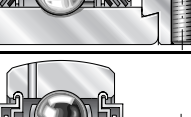
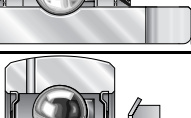
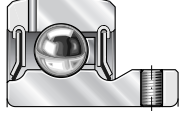
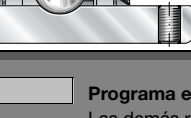

Información Técnica de Producto TPI 106

# Rodamientos autoalineables con soportes de fundición – Programa estándar

	 <b>GG ASE</b> d = 12 a 120	 <b>GG SAO</b> d = 30 a 100 serie pesada	 <b>GG SHE</b> d = 12 a 60	 <b>GG LCTE</b> d = 12 a 40 sin agujero de engrase	 <b>GG GLCTE</b> d = 12 a 40
	<b>RAE..NPPB</b> d = 12 a 50 (sin 45) sin agujeros de engrase				<b>FLCTE</b> d = 12 a 40
	<b>GRAE..NPPB</b> d = 12 a 60	<b>PASE</b> d = 12 a 60		<b>PSHE</b> d = 12 a 60	
	<b>GE..KRRB</b> d = 17 a 120	<b>RASE</b> d = 17 a 120		<b>RSHE</b> d = 17 a 60	
	<b>GNE..KRRB</b> d = 30 a 100 serie pesada		<b>RSAO</b> d = 30 a 100		
	<b>GE..KPPB-3</b> d = 20 a 80 con obturaciones de 3 labios	<b>TASE</b> d = 20 a 80		<b>TSHE</b> d = 20 a 60	
	<b>GE..KLLHB</b> d = 20 a 50 con obturaciones de laberinto	<b>LASE</b> d = 20 a 50		<b>LSHE</b> Sobre consulta	
	<b>GLE..KRRB</b> d = 20 a 70 rodamientos libres	<b>RASEL</b> d = 20 a 70			
	<b>GSH..RRB</b> d = 20 a 50 rodamientos con manguitos de fijación	<b>RASEA</b> d = 20 a 40		<b>RSHEA</b> Sobre consulta	
	<b>AY..NPPB</b> d = 12 a 30 sin agujeros de engrase				<b>FLCTEY</b> d = 12 a 30
	<b>GAY..NPPB</b> d = 12 a 60	<b>PASEY</b> d = 12 a 60		<b>PSHEY</b> d = 12 a 60	<b>FLCTEY</b> d = 35 a 40
	<b>GYE..KRRB</b> d = 12 a 90	<b>RASEY</b> d = 12 a 90		<b>RSHEY</b> d = 15 a 60	<b>GLCTEY</b> Sobre consulta

**Programa estándar**

Las demás referencias muestran otras posibilidades de combinación.  
 Suministro sobre consulta.

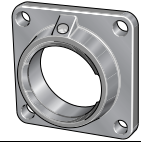
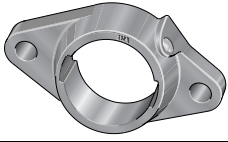

<b>GG CJT</b> d = 12 a 75	<b>GG CJTZ</b> d = 20 a 60 con resalte de centrado	<b>GG CFT</b> d = 12 a 50 altura menor que CJT
------------------------------	---	---

<b>GG ME</b> d = 20 a 120	<b>GG MEO</b> d = 30 a 100 serie pesada
------------------------------	---

<b>GG FE</b> d = 25 a 60
-----------------------------

<b>GG CJ</b> d = 12 a 120	<b>GG CJO</b> d = 30 a 100 serie pesada	<b>GG CF</b> d = 20 a 50 altura menor que CJT
------------------------------	---	--

<b>PCJT</b> d = 12 a 60		<b>PCFT</b> d = 12 a 50
<b>RCJT</b> d = 17 a 75	<b>RCJTZ</b> d = 20 a 60	
<b>TCJT</b> d = 20 a 75		
<b>LCJT</b> d = 20 a 50		
<b>RCJTL</b> Sobre consulta		
<b>RCJTA</b> d = 20 a 40		
<b>PCJTY</b> d = 12 a 60		<b>PCFTY</b> Sobre consulta
<b>RCJTY</b> d = 12 a 75		

<b>PME</b> d = 20 a 60	
<b>RME</b> d = 20 a 120	
	<b>RMEO</b> d = 30 a 100
<b>TME</b> d = 20 a 80	
<b>LME</b> Sobre consulta	
<b>RMEL</b> Sobre consulta	
<b>RMEA</b> Sobre consulta	
<b>PMEY</b> d = 20 a 60	
<b>RMEY</b> d = 20 a 90	

<b>RFE</b> d = 25 a 60
<b>TFE</b> d = 25 a 60

<b>PCJ</b> d = 12 a 60		<b>PCF</b> d = 20 a 50
<b>RCJ</b> d = 17 a 120		
	<b>RCJO</b> d = 30 a 100	
<b>TCJ</b> d = 20 a 80		
<b>RCJL</b> d = 30 a 70		
<b>RCJA</b> Sobre consulta		
<b>PCJY</b> d = 12 a 60		
<b>RCJY</b> d = 12 a 90		

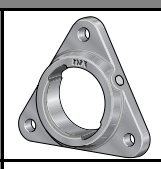

**GG CFTR**  
d = 12 a 50

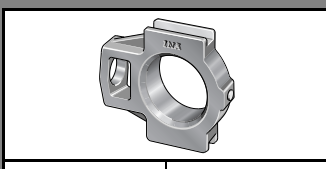

**GG TUE**  
d = 20 a 120

**GG TUEO**  
d = 80 a 100  
serie pesada

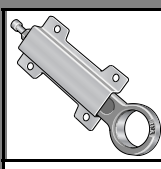

**HUSE  
HUE**  
d = 20 a 50

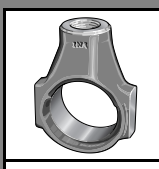

**GG HE**  
d = 20 a 50



**GG SFT**  
d = 20 a 35

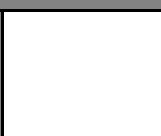
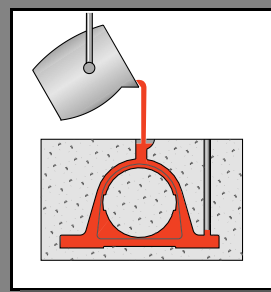

**PCFTR**  
d = 12 a 50

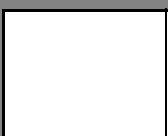

**PTUE**  
d = 20 a 60

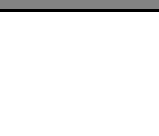

**RTUE**  
d = 20 a 120

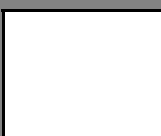

**PHUSE**  
d = 25 a 50

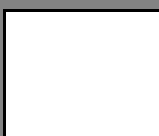

**PHE**  
d = 20 a 50

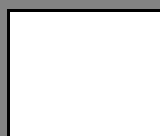

**PSFT**  
d = 20 a 35

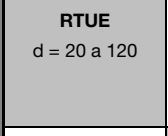
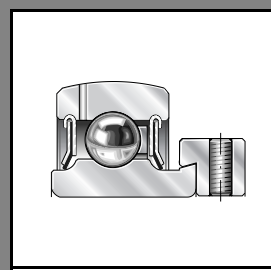

**TTUE**  
d = 20 a 80

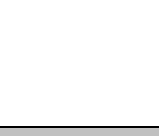

**RTUEO**  
d = 80 a 100



**RHE**  
d = 20 a 50

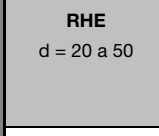

**THE**  
d = 20 a 50

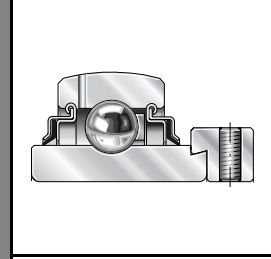

**RTUEL**  
Sobre consulta



**PHEY**  
d = 20 a 45



**PHEY**  
d = 20 a 45

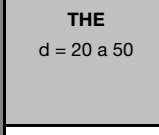

**PHEY**  
d = 20 a 45

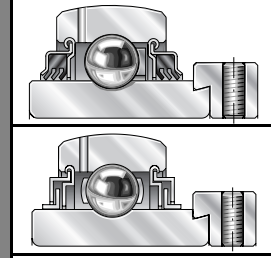

**PTUEY**  
d = 20 a 60



**RTUEY**  
d = 20 a 80



**RTUEY**  
d = 20 a 80



**RTUEY**  
d = 20 a 80



**RTUEY**  
d = 20 a 80

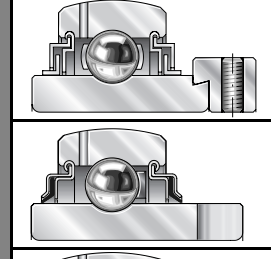

**RTUEY**  
d = 20 a 80

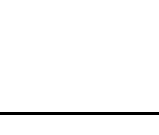

**RTUEY**  
d = 20 a 80



**RTUEY**  
d = 20 a 80

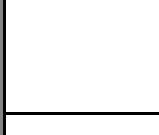

**RTUEY**  
d = 20 a 80

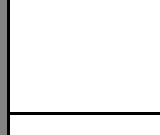

**RTUEY**  
d = 20 a 80

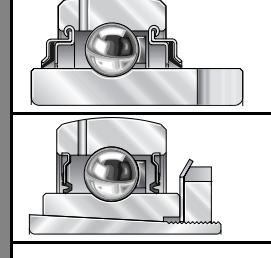

**RTUEY**  
d = 20 a 80



**RTUEY**  
d = 20 a 80



**RTUEY**  
d = 20 a 80



**RTUEY**  
d = 20 a 80

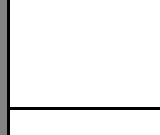

**RTUEY**  
d = 20 a 80

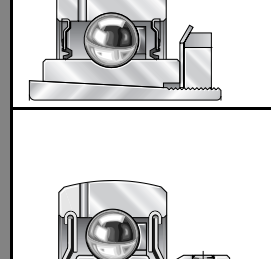

**RTUEY**  
d = 20 a 80



**RTUEY**  
d = 20 a 80



**RTUEY**  
d = 20 a 80

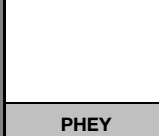

**RTUEY**  
d = 20 a 80



**RTUEY**  
d = 20 a 80

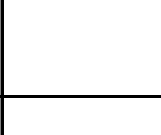
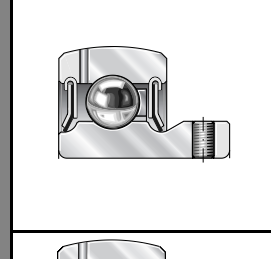

**RTUEY**  
d = 20 a 80

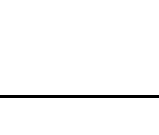

**RTUEY**  
d = 20 a 80

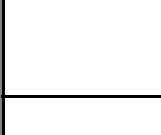

**RTUEY**  
d = 20 a 80

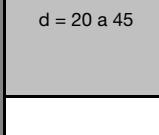



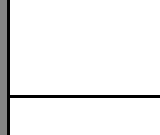



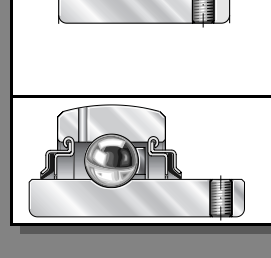

**RTUEY**  
d = 20 a 80

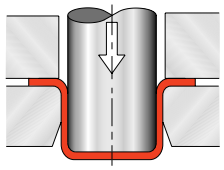

**RTUEY**  
d = 20 a 80

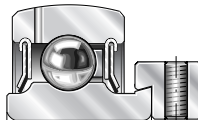
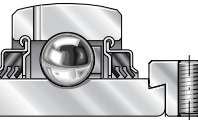
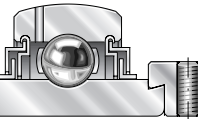
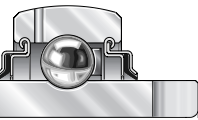
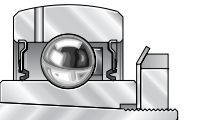

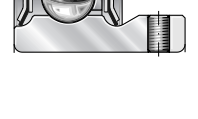
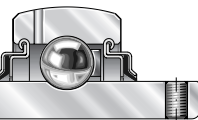
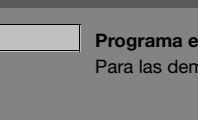
# Rodamientos autoalineables con soportes de chapa de acero

	 <b>GEH PBS</b> d = 12 a 40	 <b>GEH BT</b> d = 12 a 30	 <b>GEH BT GRG</b> d = 12 a 30	 <b>LST</b> (2 piezas) d = 20, 25		<b>MST</b> (2 piezas) d = 12 a 40	
 <b>RALE..NPPB</b> d = 20 a 30 serie ligera, sin agujeros de engrase				<b>RPB</b> d = 30	<b>RALT</b> d = 20, 25		
 <b>RAE..NPPB</b> d = 12 a 50 (sin 45) sin agujeros de engrase		<b>PBS</b> d = 12 a 40	<b>PB</b> d = 12 a 30	<b>RPB</b> d = 12 a 25		<b>RAT</b> d = 12 a 40	
 <b>GRAE..NPPB</b> d = 12 a 60							
 <b>GE..KRRB</b> d = 17 a 120		<b>RBS</b> d = 17 a 40	<b>RB</b> d = 17 a 30			<b>RRT</b> d = 17 a 40	
 <b>GE..KPPB-3</b> d = 20 a 80 con obturaciones de 3 labios		<b>TBS</b> d = 20 a 40	<b>TB</b> d = 20 a 30			<b>RTT</b> d = 20 a 40	
 <b>GE..KLLHB</b> d = 20 a 50 con obturaciones de laberinto		<b>LBS</b> d = 20 a 40	<b>LB</b> d = 20 a 30			<b>RLT</b> d = 20 a 40	
 <b>GLE..KRRB</b> d = 20 a 70 rodamientos libres		<b>RBSL</b> d = 20 a 40	<b>RBL</b> d = 20 a 30			<b>RRTL</b> d = 20 a 40	
 <b>GSH..RRB</b> d = 20 a 50 rodamientos con manguitos de fijación		<b>RBSA</b> d = 20 a 40	<b>RBA</b> d = 20 a 30			<b>RRTA</b> d = 20 a 40	
 <b>AY..NPPB</b> d = 12 a 30 sin agujeros de engrase		<b>PBSY</b> d = 12 a 30	<b>PBY</b> d = 12 a 30			<b>RATY</b> d = 12 a 30	
 <b>GAY..NPPB</b> d = 12 a 60		<b>PBSY</b> d = 35 a 40				<b>RATY</b> d = 35 a 40	
 <b>GYE..KRRB</b> d = 12 a 90		<b>RBSY</b> d = 12 a 40	<b>RBY</b> d = 12 a 30			<b>RRTY</b> d = 12 a 40	

Programa estándar

Para las demás referencias los soportes y los rodamientos deben pedirse por separado y se suministran también por separado.

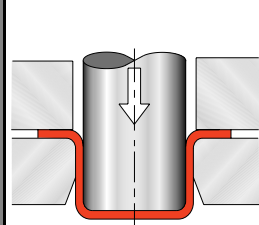
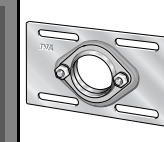
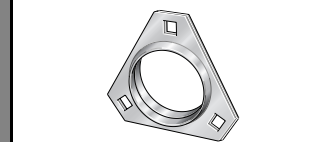
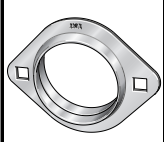

**CSLT  
CST**  
d = 20 a 30

**RCSMF  
GRG**  
d = 12 a 30

**MSB**  
(2 piezas)  
d = 12 a 60

**MSA  
MSB**  
d = 20 a 50  
reengrasables

**LSTR**  
(2 piezas)  
d = 20 a 30  
serie ligera

**MSTR**  
(2 piezas)  
d = 20 a 35

**GEH  
MSTU**  
d = 25 a 30

**PCSLT**  
d = 20 a 30

**RCSMF**  
d = 12 a 30

**RA**  
d = 12 a 40

**GRA**  
d = 20 a 50

**RALTR**  
d = 20 a 30

**RATR**  
d = 20 a 35

**MSTU**  
d = 25 a 30

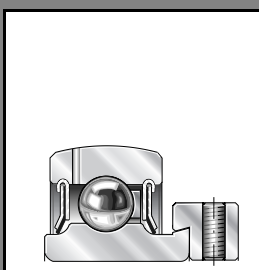

**RR**  
d = 17 a 60

**GRR**  
d = 20 a 50

**TR**  
d = 20 a 60

**GTR**  
d = 20 a 50

**RRTR**  
d = 20 a 35

**RTTR**  
d = 20 a 35

**RRTR**  
d = 20 a 35



**LR**  
d = 20 a 50

**GLR**  
d = 20 a 50

**RRL**  
d = 20 a 60

**GRRL**  
d = 20 a 50

**RLTR**  
d = 20 a 35

**RRTRL**  
d = 20 a 35

**RRTR**  
d = 20 a 35

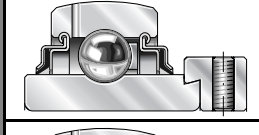

**RRA**  
d = 20 a 40

**GRRA**  
d = 20 a 40

**RAY**  
d = 12 a 30

**RATRY**  
d = 20 a 30

**RRTRA**  
d = 20 a 35

**RATRY**  
d = 20 a 30

**RRTRA**  
d = 20 a 35

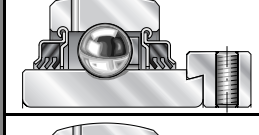

**RAY**  
d = 35 a 60

**GRAY**  
d = 20 a 50

**RRY**  
d = 12 a 60

**GRRY**  
d = 20 a 50

**RATRY**  
d = 35

**RRTRY**  
d = 20 a 35

**RRTRY**  
d = 20 a 35

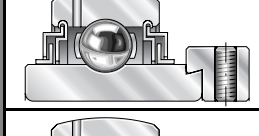

**RRY**  
d = 12 a 60

**GRRY**  
d = 20 a 50

**RRY**  
d = 12 a 60

**GRRY**  
d = 20 a 50

**RRY**  
d = 12 a 60

**GRRY**  
d = 20 a 50

**RRY**  
d = 12 a 60

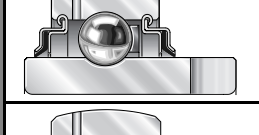

**RRY**  
d = 12 a 60

**GRRY**  
d = 20 a 50

**RRY**  
d = 12 a 60

**GRRY**  
d = 20 a 50

**RRY**  
d = 12 a 60

**GRRY**  
d = 20 a 50

**RRY**  
d = 12 a 60

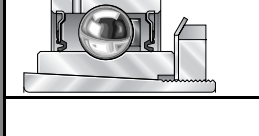

**RRY**  
d = 12 a 60

**GRRY**  
d = 20 a 50

**RRY**  
d = 12 a 60

**GRRY**  
d = 20 a 50

**RRY**  
d = 12 a 60

**GRRY**  
d = 20 a 50

**RRY**  
d = 12 a 60

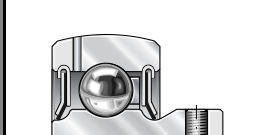

**RRY**  
d = 12 a 60

**GRRY**  
d = 20 a 50

**RRY**  
d = 12 a 60

**GRRY**  
d = 20 a 50

**RRY**  
d = 12 a 60

**GRRY**  
d = 20 a 50

**RRY**  
d = 12 a 60

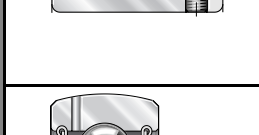

**RRY**  
d = 12 a 60

**GRRY**  
d = 20 a 50

**RRY**  
d = 12 a 60

**GRRY**  
d = 20 a 50

**RRY**  
d = 12 a 60





**GRRY**  
d = 20 a 50

**RRY**  
d = 12 a 60





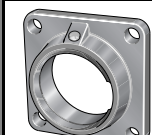
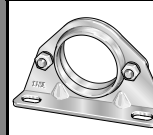
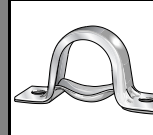
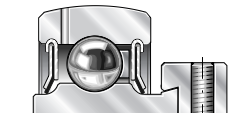

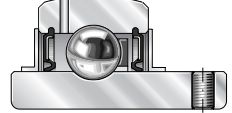

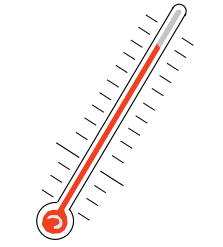

## Soportes de fundición protegidos contra la corrosión

## Rodamientos

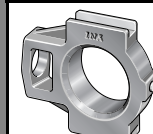
	 <p><b>GG ASE..FA 125</b> d = 12 a 60</p>	 <p><b>GG CJT..FA 125</b> d = 12 a 60</p>	 <p><b>GG CJ..FA 125</b> d = 12 a 60</p>	 <p><b>GEH PBS</b> d = 12 a 40</p>	 <p><b>GEH BT</b> d = 12 a 30</p>
 <p><b>GRAE..NPPB FA 125</b> d = 12 a 60</p>	<p><b>PASE..FA 125</b> d = 12 a 60</p>	<p><b>PCJT..FA 125</b> d = 12 a 60</p>	<p><b>PCJ..FA 125</b> d = 12 a 60</p>	<p><b>PBS..FA 125</b> d = 12 a 40</p>	<p><b>PB..FA 125</b> d = 12 a 30</p>
 <p><b>GE..KRRB FA 125</b> d = 20 a 50</p>	<p><b>RASE..FA 125</b> d = 20 a 50</p>	<p><b>RCJT..FA 125</b> d = 20 a 50</p>	<p><b>RCJ..FA 125</b> d = 20 a 50</p>	<p><b>RBS..FA 125</b> d = 20 a 40</p>	<p><b>RB..FA 125</b> d = 20 a 30</p>
 <p><b>GYE..KRRB VA</b> d = 12 a 40</p>					

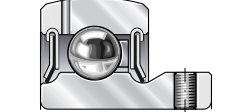
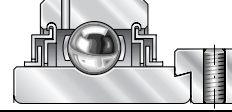
## Soportes de fundición para altas temperaturas

	 <p><b>GG ASE</b> d = 12 a 120</p>	 <p><b>GG CJT</b> d = 12 a 75</p>	 <p><b>GG CJ</b> d = 12 a 120</p>	 <p><b>GG TUE</b> d = 20 a 120</p>
 <p><b>GE..KRRB FA 101T</b> d = sobre consulta para temperaturas de -40 °C a +150 °C</p>	<p><b>RASE..FA 101T</b> Sobre consulta</p>	<p><b>RCJT..FA 101T</b> Sobre consulta</p>	<p><b>RCJ..FA 101T</b> Sobre consulta</p>	<p><b>RTUE..FA 101T</b> Sobre consulta</p>
 <p><b>GE..KRRB FA 164.1</b> d = 17 a 120 para temperaturas de -20 °C a +250 °C</p>	<p><b>RASE..FA 164.1</b> d = 20 a 120</p>	<p><b>RCJT..FA 164.1</b> d = 30 a 50</p>	<p><b>RCJ..FA 164.1</b> d = 25 a 90</p>	<p><b>RTUE..FA 164.1</b> Sobre consulta</p>
 <p><b>GAY..NPPB FA 164.1</b> d = 12 y 15 para temperaturas de -20 °C a +250 °C</p>	<p><b>PASEY..FA 164.1</b> d = 12, 15</p>	<p><b>PCJTY..FA 164.1</b> d = 12, 15</p>	<p><b>PCJY..FA 164.1</b> d = 12, 15</p>	
 <p><b>GE..KLLHB</b> d = 20 a 50 con obturaciones de laberinto para temperaturas de -40 °C a +150 °C</p>	<p><b>LASE</b> d = 20 a 50</p>	<p><b>LCJT</b> d = 20 a 50</p>	<p><b>LCJ</b> Sobre consulta</p>	
 <p><b>GLE..KRRB</b> d = 20 a 70, rodamientos libres para temperaturas de -40 °C a +150 °C</p>	<p><b>RASEL</b> d = 20 a 70</p>	<p><b>RCJTL</b> Sobre consulta</p>	<p><b>RCJL</b> d = 20 a 70</p>	<p><b>RTUEL</b> Sobre consulta</p>

# autoalineables y soportes de chapa de acero

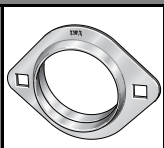
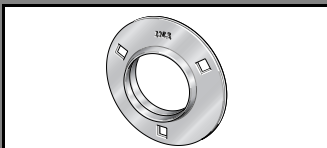
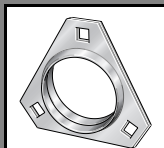
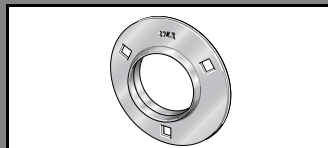
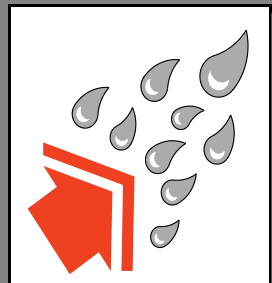
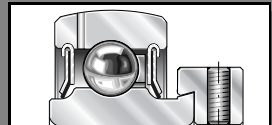
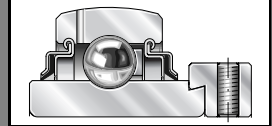
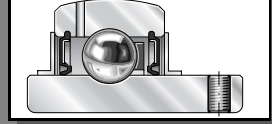
							
<b>MST..FA 125</b> (2 piezas) d = 12 a 40	<b>MSB..FA 125</b> (2 piezas) d = 12 a 60	<b>MSA..FA 125</b> <b>MSB..FA 125</b> d = 20 a 50 reengrasables	<b>MSTR..FA 125</b> d = 20 a 35	<b>MSB..VA</b> (2 piezas) d = 12 a 30	<b>MSA..VA</b> <b>MSB..VA</b> d = 20 a 30 reengrasables		
<b>RAT..FA 125</b> d = 12 a 40	<b>RA..FA 125</b> d = 12 a 60	<b>GRA..FA 125</b> d = 20 a 50	<b>RATR..FA 125</b> d = 20 a 35				
<b>RRT..FA 125</b> d = 20 a 40	<b>RR..FA 125</b> d = 20 a 50	<b>GRR..FA 125</b> d = 20 a 50	<b>RRTR..FA 125</b> d = 20 a 35				
				<b>RRY..VA</b> d = 12 a 30	<b>GRRY..VA</b> d = 20 a 30		

Los soportes de chapa de acero y los rodamientos deben pedirse por separado y se suministran también por separado.  
 FA 125 = Recubrimiento especial Corrotect® de INA (recubrimiento de cinc-hierro-cobalto).  
 VA = Acero inoxidable.

## Tapas de protección

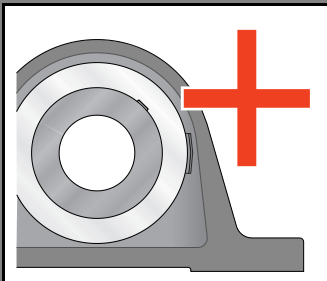

INA puede suministrar, como accesorio, tapas de protección de plástico para cubrir los extremos libres de los ejes:

- así se asegura la protección contra accidentes cuando el eje está en rotación
- protección adicional contra la entrada de suciedad o impurezas.

Las tapas de protección están disponibles para:

- los soportes autoalineables PASE..., PASE..FA125, RASE..., RASE..FA125, PSHE..., RSHE..., PCJT..., PCJT..FA125, RCJT..., RCJT..FA125, PME..., RME..., PCJ..., PCJ..FA125, RCJ..., RCJ..FA125 con diámetro de eje de 20, 25, 30, 35, 40, 50 y 60 mm.

Otros soportes, sobre consulta

Los soportes disponen de una ranura para la fijación de las tapas de protección situada en el lado del anillo tensor excéntrico.

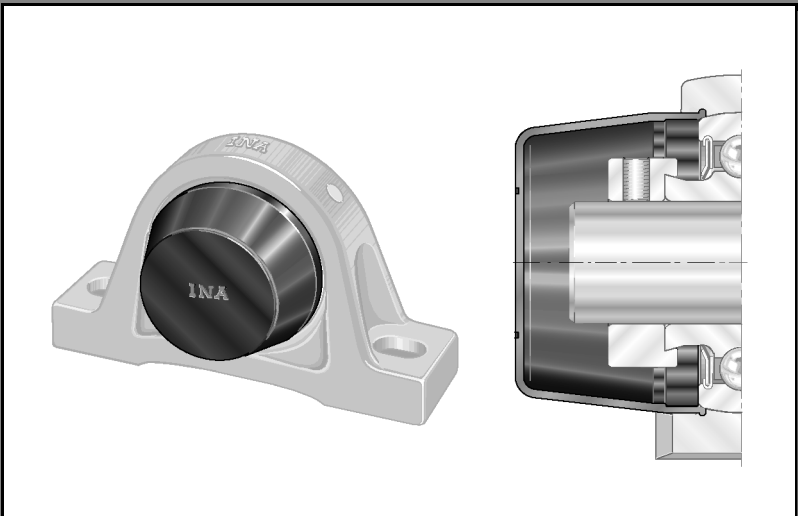
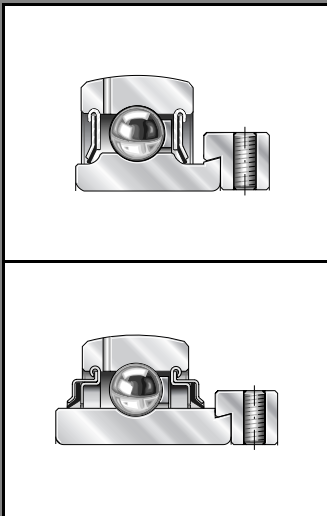



# Características y selección de los soportes autoalineables

Los soportes autoalineables INA son elementos de máquina robustos, listos para el montaje y fáciles de montar. Permiten sistemas de apoyo fiables y económicos que funcionan perfectamente tanto en condiciones de utilización normales como en ambientes húmedos o con fuerte suciedad.

Estas unidades, que son apreciadas ya desde hace tiempo, se suministran en varias series y se componen de forma estándar de:

- soportes de apoyo o soportes-brida y
- rodamientos autoalineables engrasados y obturados por ambos lados.

## Soportes de fundición gris o de chapa de acero

Los soportes son de fundición gris o de chapa de acero.

Los soportes de fundición gris son de una sola pieza, soportan elevadas cargas y disponen de un agujero roscado para fijar un engrasador para lubricar los rodamientos autoalineables. Los soportes de chapa embutida son en dos piezas y soportan cargas medias.

## Rodamientos autoalineables

Los rodamientos autoalineables tienen un anillo exterior con superficie externa esférica adaptada al agujero del soporte,

anillos interiores alargados por uno o por ambos lados y obturaciones rozantes o sin rozamiento. Estos rodamientos se fijan radialmente al eje mediante un anillo tensor excéntrico o por dos tornillos prisioneros del anillo interior.

## Compensación de errores de alineación

La ejecución específica del anillo exterior del rodamiento y del agujero esférico del soporte permite al anillo exterior posicionarse para compensar errores de alineación del eje. De esta forma se compensan las desviaciones del eje ocasionadas por imprecisiones en el montaje o por tolerancias de las construcciones anexas.

## Soportes para aplicaciones especiales

Además de las ejecuciones para aplicaciones estándar, INA puede suministrar soportes para elevadas temperaturas o con protección antioxidante.

## Catálogo INA

### "Rodamientos autoalineables y soportes"

Este catálogo describe el programa completo de INA para estos soportes y rodamientos autoalineables. Además aporta información sobre otros productos INA, como las poleas tensoras y las ruedas tensoras de cadenas.

## Rodamientos autoalineables combinados con

### Para seleccionar un soporte:

- ① Definir el cuerpo soporte
- ② Definir el rodamiento
- ③ Determinar la combinación con ayuda de la tabla  
– La zona sombreada indica el soporte del programa estándar

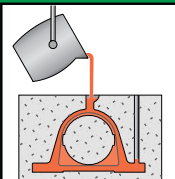
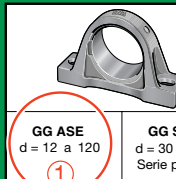
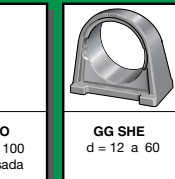
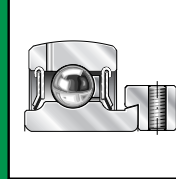
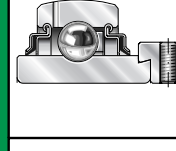
			
	GG ASE d = 12 a 120	GG SAO d = 30 a 100 Serie pesada	GG SHE d = 12 a 60
	RAE..NPPB d = 12 a 50 (excepto 45) Sin agujeros de reengrase		
	GRAE..NPPB d = 12 a 60	PASE d = 12 a 60	PSHE d = 12 a 60
	GE..KRRB d = 17 a 120	RASE d = 17 a 120	RSHE d = 17 a 60
	GNE..KRRB d = 30 a 100 Serie pesada		RSAO d = 30 a 100
	GE..KPPB	GG..SAO	



**INA Rodamientos, s.a.**

Polígono Pont Reixat  
08960 Sant Just Desvern · Barcelona  
Teléfono (93) 480 34 10 · Fax (93) 372 92 50  
E-mail: [marketing@es.ina.com](mailto:marketing@es.ina.com)  
[www.inarodamientos.es](http://www.inarodamientos.es)